

All drawings and technical documents for the manufacture of the goods or parts thereof, which the Party submitted remain the transferring Party's (intellectual) property. These may not, without the written consent of the Party (owner of the intellectual property), be used by the receiving Party, copied, reproduced, or otherwise disclosed to a third party.

Revision	Revised by	Rev. Appr. By	ECM No.

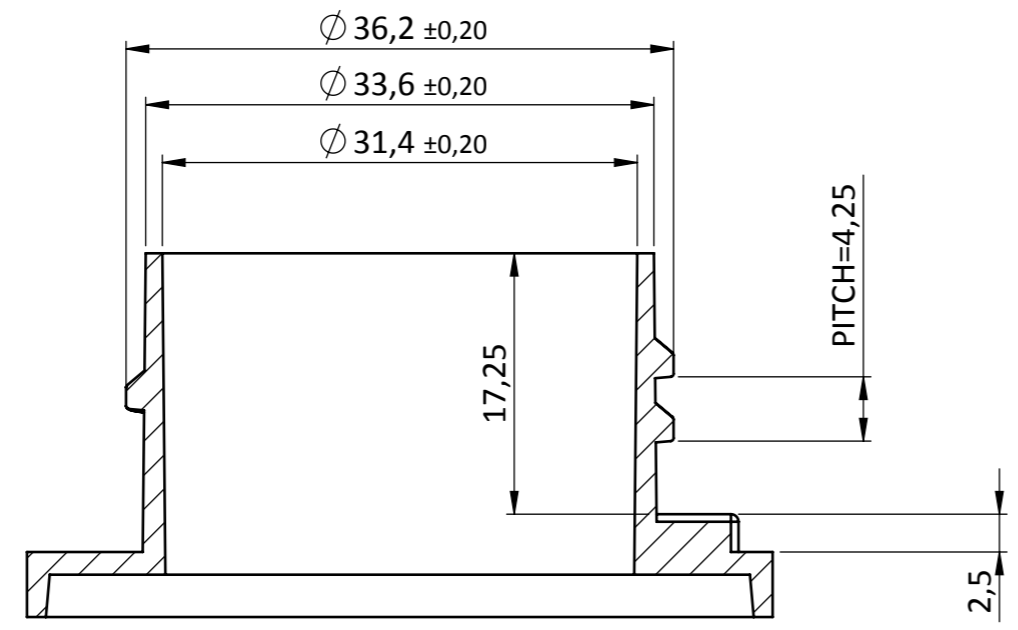

A-A

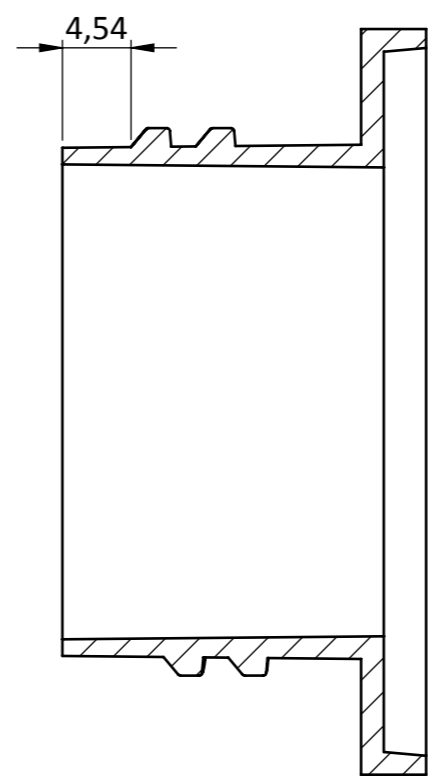
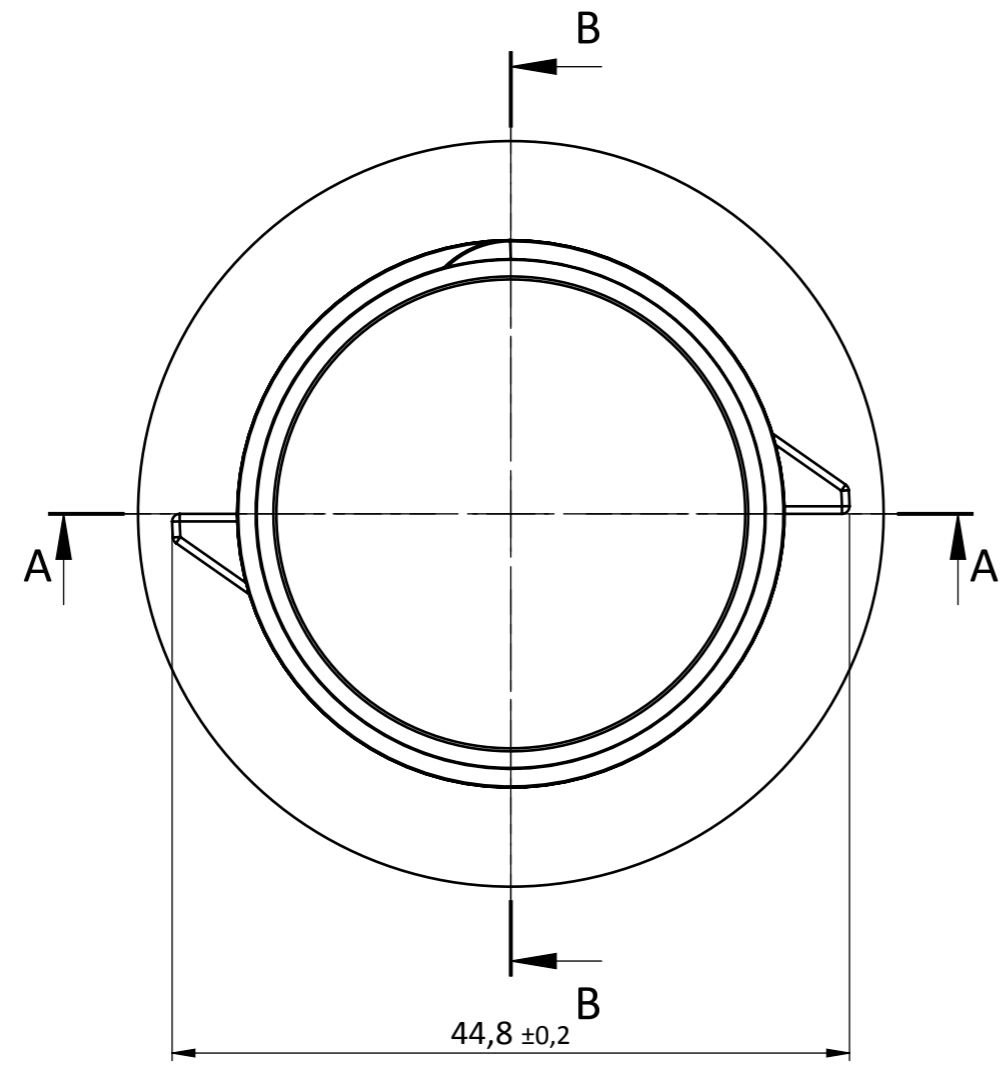

**Very Important**

The neck dimensions shown are those which have generally been found to be functional but each closure/finish system should be individually evaluated. Neck finishes having dimension outside these ranges can also be appropriate for use, therefore the bottle neck drawing is only a recommendation.

This recommendation is for following closures: 38BST, 38BOST

Drawn by/Drawn date <b>MS 2017-01-27</b>	Approved by/Approved date	Theoretical weight(g)	General Tolerance According to <b>DIN 16901-130</b>	Volume (cm <sup>3</sup> )			
 <b>Modulpac AB</b> Västergatan 16 SE-341 50 Lagan Sweden Tel. +46-(0)372-25500 Fax. +46-(0)372-25501	Description <b>HALS 38BST, 38BOST</b>		Drawing No	Format <b>A3</b>		Revision	Scale <b>2:1</b>